

The Repair Guys

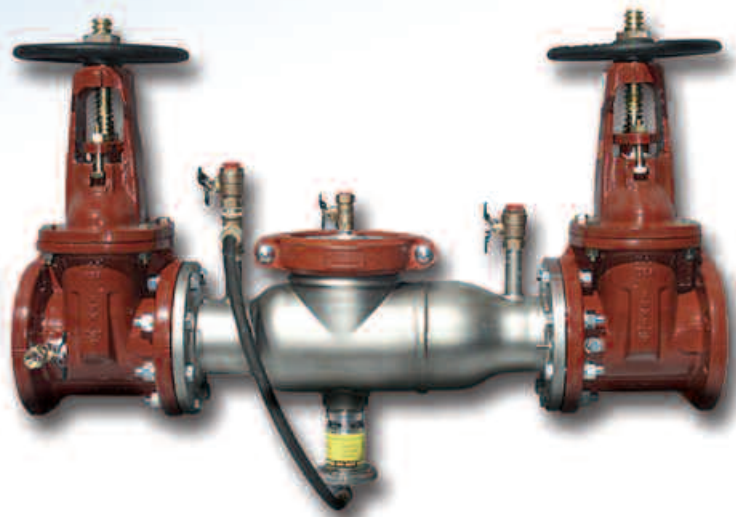

Installation of a 6 Inch Reduced Pressure Principle Assembly

Jason:

Basically, pressure loss is present in any plumbing system. It normally starts with the friction of the water against the interior walls of "fixed orifice items" such as pipe, valves, and fittings. They are called fixed orifice items simply because the

In our line of work, we field questions from contractors and technicians concerning repairs, installations, and general backflow prevention practices. We'd like to share some questions that we receive as well as our answers. Everyone has different opinions on these subjects and we would like to hear yours. Contact us with questions and ideas via email at: imark@backflowparts.com or mail us at American Backflow Products Co., PO Box 37025, Tallahassee, Florida 32315.

-- Mark Inman and Jason Gregg

Question:

I will be installing a 6 inch Reduced Pressure Principle Assembly on an existing system. Can you tell me what the "pressure loss" or CV factor is for that particular assembly?

Mark:

This question is probably the most common question that is asked by plumbing contractors, fire line contractors, and even engineers for new or retrofit backflow assembly installations. Obviously, anytime a backflow assembly is specified for an installation it is very important to know what the pressure loss is for the assembly. The problem we find many times is that the answer can be easily misunderstood. For example, when we call our supplier and ask this question, normally they will look it up and find a flow curve not a specific number. This can be confusing, so many times they may guess, or give an estimate of the overall pressure loss. It is important that we understand how it is represented on a flow curve, so that pressure loss can be calculated correctly.



pathway that the water flows does not change, so it is easy to calculate the pressure loss for that item. The pressure loss for a fixed orifice item is identified as the CV factor. A backflow prevention assembly is not a fixed orifice item so it can not have a CV factor. The check valves within the assembly are force loaded to the closed position. This means that the orifice or pathway that the water flows through is constantly changing (As the flow of water increases or decreases, the check valves are opening and closing). This opening and closing of the check valves changes the amount of friction within the assembly.

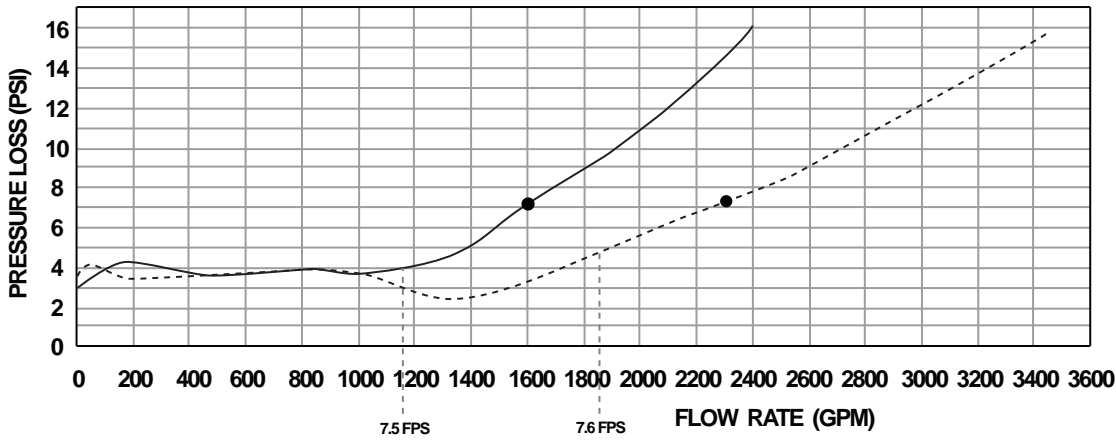

Mark:

With that in mind, the best way to show the flow characteristics of a backflow preventer is by a “pressure loss versus flow rate” curve. This type of flow curve will show the pressure loss of the assembly throughout its full range of operation not just at a single point. So, to determine the pressure loss, we need to know at what flow rate the assembly will be operating. Then it is just a matter of reading the curve. We know that as the flow rate varies, the pressure loss through the assembly will vary as well. For example, you could have a 6 inch reduced pressure principle assembly that has a pressure loss of 12 PSI at 140 GPM and then a pressure loss of 9.5 PSI at 840 GPM.

Jason:

It is important to remember that the values we get from a flow curve are for the assembly itself and does not include

any of the piping and fittings required to install the assembly. There have also been some questions concerning pressure loss tables that are published by approval agencies. These tables are used to show the “maximum allowable pressure loss” requirement for a specific size and type of backflow prevention assembly. Basically, these tables show the standard by which assemblies are evaluat-

ed by that agency or lab. To find the pressure loss for a particular model of backflow preventer, you will normally have to refer to the manufacturer's specification sheet. ▼

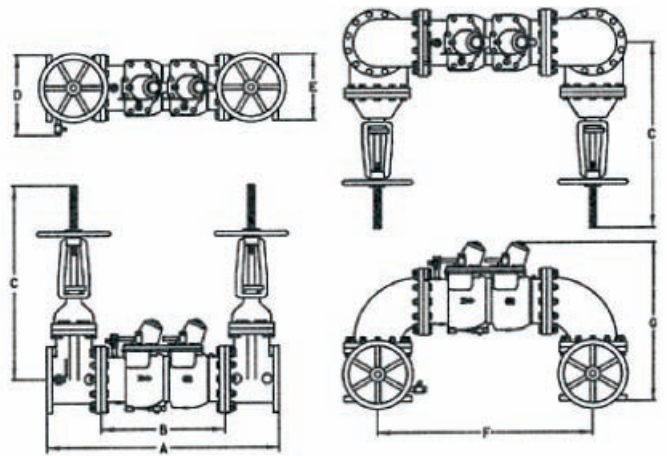

American Backflow
Products Company

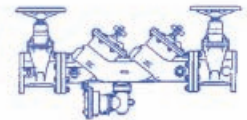

Mid-West
Instrument

WATTS
REGULATOR

SAFE-T-COVER

CLA-VAL

FLOMATIC

RAIN BIRD

**Your Complete Source For:
Backflow Preventer Repair Parts
Accessories • Enclosures
Test Gauge Calibration**

800-575-9618

www.backflowparts.com

AMES
FIRE & WATERWORKS

ZURN / WILKINS

Hersey
PRODUCTS

HOT BOX

CONBRACO
'Apollo' Valves

FEBCO